



WILDCATS



LIVE PERFORMANCE
LOUDSPEAKERS FROM **TANNOY**®

WILDCATS



LYNX

Tannoy Wildcats—The system that you asked for.

You asked for a system that adapted easily and quickly to different venues—Wildcats give you complete flexibility.

You asked for a system with 'road proof' cabinets—Wildcats are constructed from MDF, a high impact-resistant material, with protective corner plates and internal bracing to really shrug off the knocks of life on the road.

You asked for a system that sounded natural—Wildcats use the Tannoy Dual Concentric driver. A unique '2-in-One' speaker that eliminates many distortions inherent in conventional speaker designs and gives a smoothly dynamic sound. A genuine High Fidelity P.A. rig.

You asked for a system that can take high power—The Wildcats use drive units that have 'road-proven' reliability even with heavy rock bands and they regularly take the punishment of recording studio use.

The heart of the Tannoy Wildcats, Lynx is a double cabinet system with a 12" Tannoy Dual Concentric and passive cross-over in each cabinet. The unique design of the Lynx cabinet and its linking mechanism enables the Lynx to be used separately as a stereo system, or linked together to make a powerful loudspeaker with two 12" bass drivers and two HF compression drivers. For complete protection in transit each half of the Lynx can be fixed together face-to-face.

The superb flexibility of the Tannoy Lynx makes this the ideal loudspeaker for the performer in smaller venues and for audio-visual use.

THE SOUND ADVANTAGE...

The Tannoy Dual Concentric looks like a single speaker; but is in fact a direct radiator bass unit and a separate compression tweeter within the same chassis.

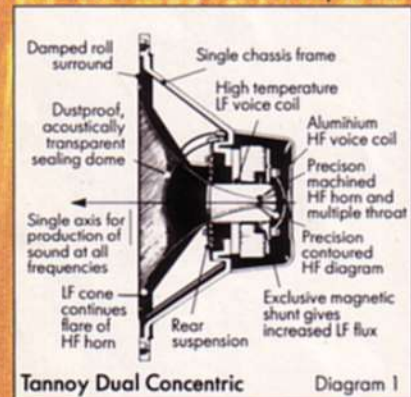

Apart from the obvious space saving advantages of this design, the Dual Concentric is a virtual single sound source speaker that reduces time smear distortion and provides a smoother frequency response, especially at the crossover point.

The Tannoy Dual Concentric's controlled dispersion also enables you to 'tailor' the sound coverage to suit your particular audience or venue. Combine this feature with the smooth frequency response and the Dual Concentric obviously provides higher sound

levels with less chance of feedback. The Wildcat system goes loud and yet also sounds good with low power amplification.

JAGUAR

The same dynamics and power as the Puma—with which it shares the same 15" version of the Tannoy Dual Concentric—are available in the Jaguar, along with extended bass response offered by the increased cabinet size. Where you require the bite of extra bass; but with limited space available the Jaguar has to be first choice.

LEOPARD

A special high power 15" bass driver within a rigidly constructed cabinet. Unlike other bass bins the Tannoy Leopard has its own internal crossover through which frequencies below 500Hz are supplied to the bass driver, while frequencies above 500Hz are made available at external sockets to drive other loudspeakers. Tannoy Leopards used in conjunction with other Wildcat loudspeakers provide a system with stupendous performance without the need for electronic crossovers, although the system can also be bi-amped by simply altering the connections on the Leopard.

...THAT GROWS WITH YOU

As well as innovative design and construction the Wildcats feature a unique system that allows rapid, easy interconnection. By incorporating a passive crossover within the Leopard bass bin and providing a mid/high frequency take off point, other Wildcat loudspeakers can be used in conjunction with the Leopard by using a single connecting lead (see diagram 2). With interconnecting leads available for both series and parallel operation, combinations of Wildcat loudspeakers can easily build into a rig to suit your exact requirements.

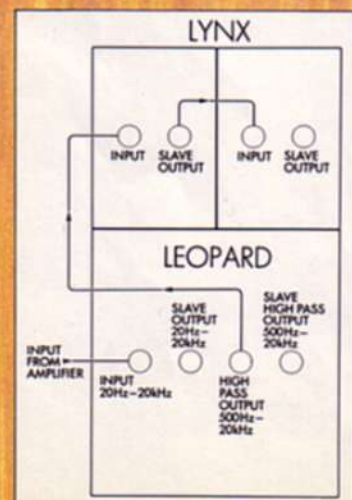
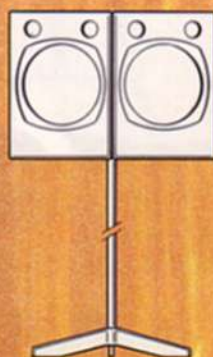

Diagram 2

Here are some example combinations of Wildcat loudspeakers that show how flexible the system is.



½ Lynx (separated)
Nominal impedance 8Ω
Power handling 200W Programme 100W RMS
Frequency response 50Hz-20kHz
Peak SPL 115dB for 200W peak input



One Lynx (linked together)
Nominal impedance 4Ω
Power handling 400W Programme 200W RMS
Frequency response 50Hz-20kHz
Peak SPL 121dB for 400W peak input

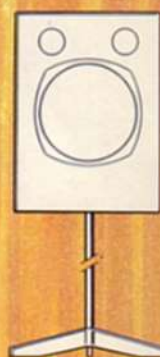



PUMA

Our little powerhouse, the Puma, packs the punch of the 15" Tannoy Dual Concentric into a remarkably compact cabinet. A high power loudspeaker, the Puma is capable of producing the high sound levels necessary for disco use yet with a smoothness and accuracy of sound previously unknown in this type of application. The live performer will also appreciate the improvement in his presentation offered by the outstanding dynamic characteristics of the Puma.



PANTHER

A powerful yet compact horn loaded loudspeaker, that is made possible by the unique Tannoy Dual Concentric 2 speakers-in-one driver. With conventional separate tweeter and bass units, a horn loaded cabinet would have to be very much larger.

The Panther is a highly efficient loudspeaker that will produce very high sound levels from some surprisingly low powered amplifiers and will give added presence to any performance.



COUGAR

The stage wedge monitor that all performers need. The compact Tannoy Dual Concentric driver gives real dynamics with full frequency response and the punch of a 15" bass unit. All this within a modestly sized cabinet that fits unobtrusively into any stage setting.



m is.

One Puma
Nominal impedance 8Ω
Power handling 300W Programme 150W RMS
Frequency response 50Hz-20kHz
Peak SPL 119dB for 300W peak input



**One Lynx
Two Leopard**
Nominal impedance 4Ω
Power handling 800W Programme 400W RMS (35Hz-500Hz)
400W Programme (500Hz-20kHz)
400W Programme 200W RMS
Frequency response 25Hz-20kHz
Peak SPL 126dB (35-500Hz) for 800W peak input
121dB (500Hz-20kHz) for 400W peak input

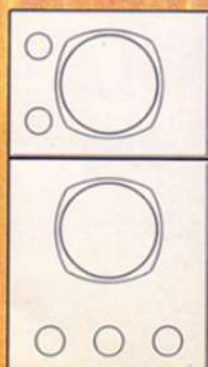

**One Puma
One Leopard**
Nominal impedance 8Ω
Power handling 400W Programme 200W RMS (35Hz-500Hz)
300W Programme 150W RMS
Frequency response 25Hz-20kHz
Peak SPL 120dB (35-500Hz) for 400W peak input
119dB (500Hz-20kHz) for 300W peak input

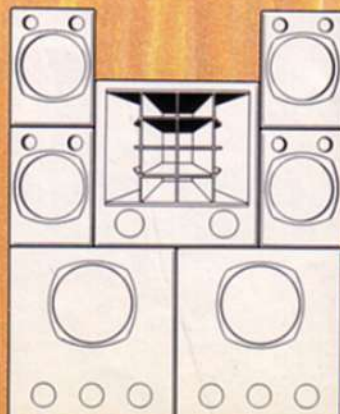

2 x ½ Lynx (stacked) + Panther + 2 x ½ Lynx (stacked) + 2 x Leopard
Multi power system
Power handling 1600W programme 800W RMS
System response 25Hz-20kHz
Peak SPL (35-500Hz) 129dB for 1600W peak
On axis (500Hz-20kHz) 132dB for 800W peak
Off axis (500Hz-20kHz) 124dB for 800W peak

WILDCATS



SPECIFICATIONS

	LYNX	PUMA	JAGUAR	PANTHER	LEOPARD	COUGAR
Price	2179.-	2179.-	2679.-	3319.-	2179.-	1999.-
Power Handling Programme*	400W (5)	300W	300W	200W	400W	300W
Power Handling RMS (1)*	200W (5)	150W	150W	100W	200W	150W
Frequency Response (2)	50Hz-20kHz	50Hz-20kHz	35Hz-20kHz	80Hz-20kHz	35Hz-500Hz	100Hz-20kHz
Sensitivity for 2.8V @ 1M over Rated Frequency Response (3)*	95dB	94dB	94dB	103dB	94dB	96dB
Impedance Nominal	4Ω	8Ω	8Ω	6Ω	8Ω	8Ω
Impedance Minimum	3Ω	5.5Ω	5.5Ω	4Ω	5.5Ω	5.5Ω
Dispersion	115° Horizontal 90° Vertical	90° Conical	90° Conical	60° Conical	180° Conical	90° Conical
Crossover Frequency	2.2kHz	1.8kHz	1.8kHz	1kHz	500Hz	1.8kHz
Internal Volume	2x44 litres	104 litres	210 litres	140 litres (4)	210 litres	46 litres
Dimensions mm (h x w x d)	490x730x412(6)	490x730x420	730x730x526	730x730x526	730x730x526	560x560x406
Dimensions inches	19.3x28.7x16.2	19.3x28.7x16.5	28.7x28.7x20.7	28.7x28.7x20.8	28.7x28.7x20.7	22x22x16
Weight kg	42	33	50	58	49	25
Weight lbs	92.5	72.5	110	128	108	55
Connections	2xXLR	2xXLR	2xXLR	2xXLR	4xXLR	2xXLR
Mounting Detail	25mm plain socket, 3/8 Whit Threaded-hole	25mm plain socket	25mm plain socket	Castor holes	Castor holes	—

Notes:

- (1) Lower limit of frequency response up to crossover frequency. Above crossover frequency power is -3dB less.
 (2) ±3dB at any power up to RMS rating.
 (3) 2.8V.

- (4) Reflex volume.
 (5) Total power for 1 double cabinet.
 (6) When packed for transit 490x730x366. Each half 490x366x412.

*Our power handling and sensitivity figures are taken over the entire frequency range of the particular product. Some other manufacturers measure a limited and often very favourable bandwidth.

ACCESSORIES

- WPL 1 0.5 Metre (1.6 feet) parallel interconnecting lead with XLR plugs.
 WPL 2 2.0 Metre (6.6 feet) parallel interconnecting lead with XLR plugs.
 WSL 1 2.0 Metre (6.6 feet) series interconnecting lead with XLR plugs.
 WA 1 Adaptor base to mount Lynx double cabinet on tripod stand.
 WT B Tiebar extender for strapping together two Lynx double cabinets.
 WTS Adjustable height tripod stand for Lynx and Puma.

TANNOY

Tannoy Ltd.
 Beadman Street, West Norwood, London SE27 0PW
 Telephone: 01-670 1131. Telex: 291065

TANNOY®

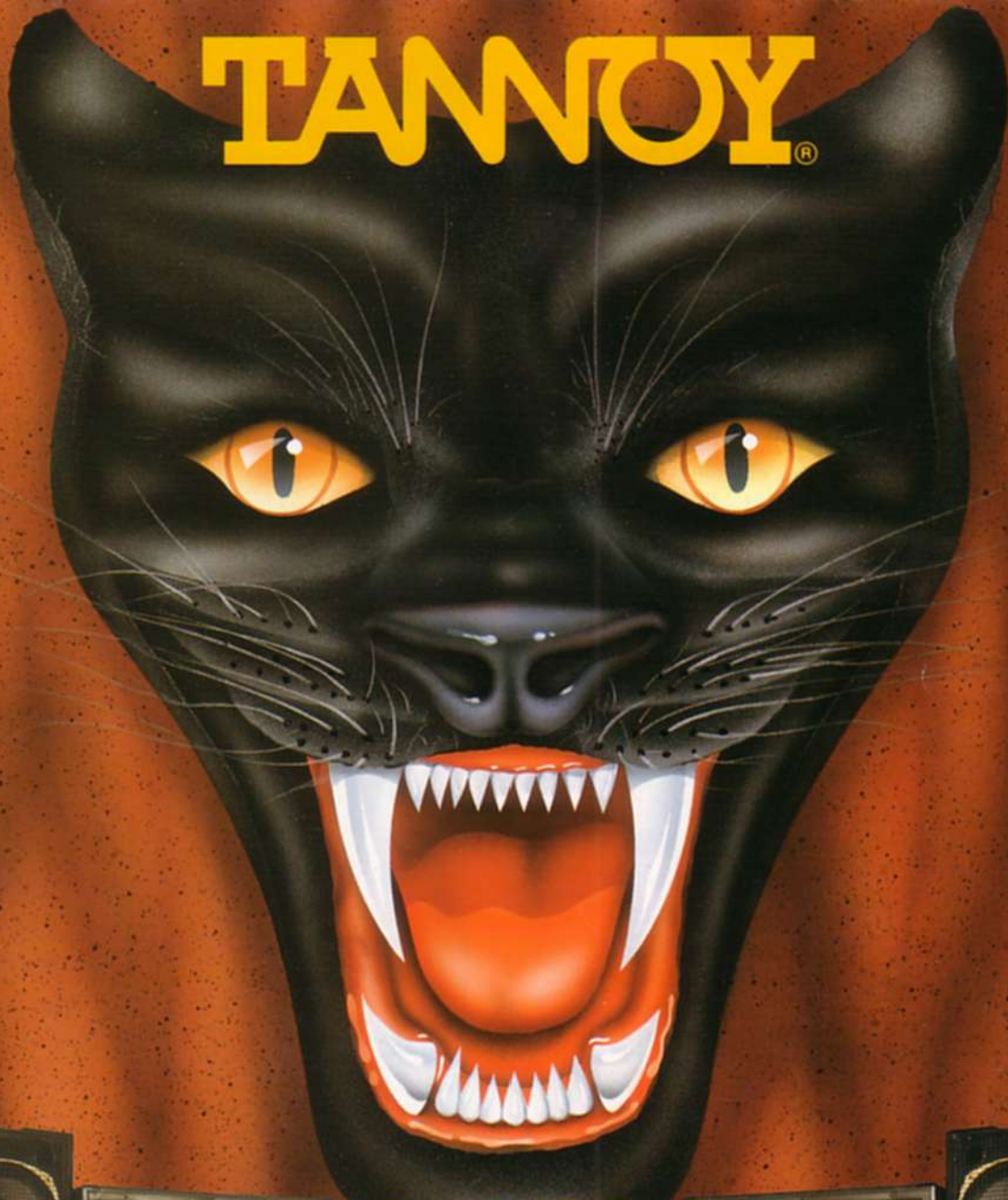

WILDCATS

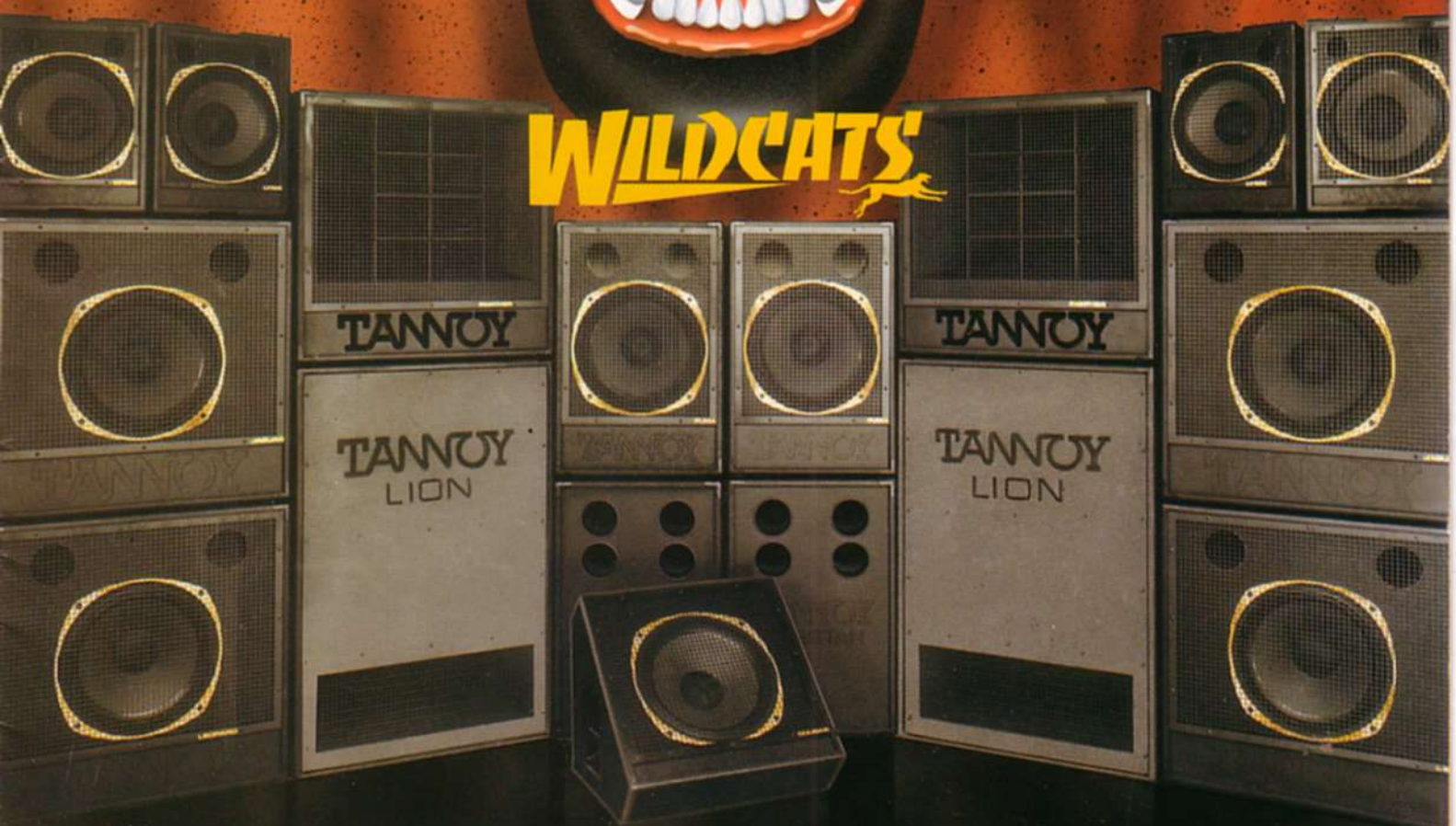

WILDCATS



Tannoy Wildcats are a truly modular PA. system which can be easily configured to suit different venues and applications.

The heart of the system is the Tannoy dual concentric drive unit – a unique “Two in One” transducer that eliminates many distortions inherent in conventional loudspeaker designs, ensuring a smoothly dynamic result; a genuine High Fidelity PA. Rig. Tannoy dual concentrics have been used in professional applications for many years, from heavy rock bands to country & western, from broadcast to music recording studios.

In order to meet the demanding conditions of road use, the cabinets are manufactured using water and boil proof Finnish birch plywood surrounds and baffles constructed with MDF, a high impact-resistant material. To further shrug off the knocks of road life, specially tooled interlocking steel corner plates are fitted along with rugged metal carrying handles.

THE SOUND ADVANTAGE...

The Tannoy Dual Concentric looks like a single speaker, but is in fact a direct radiator bass unit and a separate high frequency compression driver within the same chassis.

Apart from the obvious space saving advantages of this design, the dual concentric is a virtual single sound source speaker that reduces time smear distortion and provides a smoother frequency response, especially at the crossover point.

The Tannoy dual concentric's controlled dispersion also enables you to 'tailor' the sound coverage to suit your particular audience or venue. Combine this feature with the smooth frequency response and the dual concentric obviously provides higher sound levels with less chance of feedback.

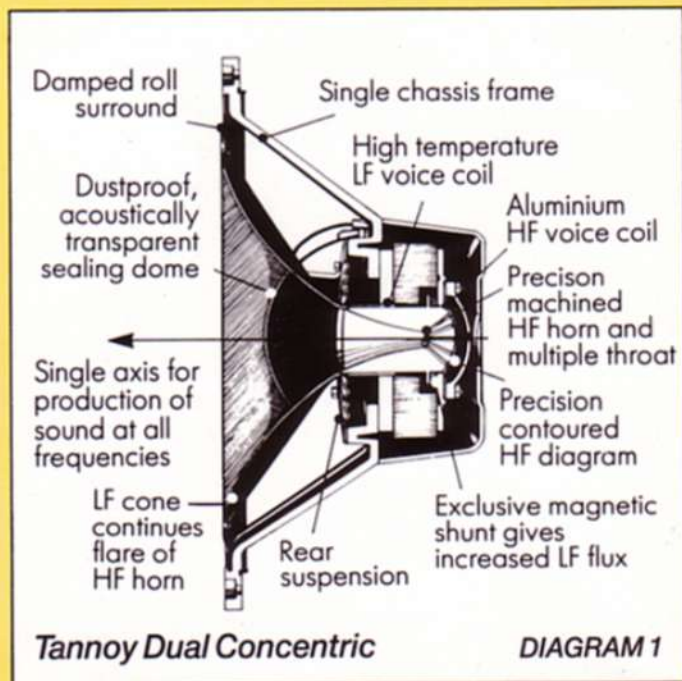

Tannoy are world leaders in this design, having produced more dual concentric loudspeakers than any other manufacturer. High power handling and reliability are ensured by black chrome plated magnet plates for greater heat dissipation from the high temperature voice coils.

...THAT GROWS WITH YOU

As well as innovative design and construction, the Wildcats feature a unique system that allows rapid, easy interconnection. By incorporating a passive crossover within the bass bins and providing a mid/high frequency take off point, other Wildcat loudspeakers can be used in conjunction with them by using a single connecting lead (see diagram 2). With interconnecting made possible for both series and parallel operation, combinations of Wildcat loudspeakers can easily build into a rig to suit your exact requirements. (see diagrams 3A & 3B).

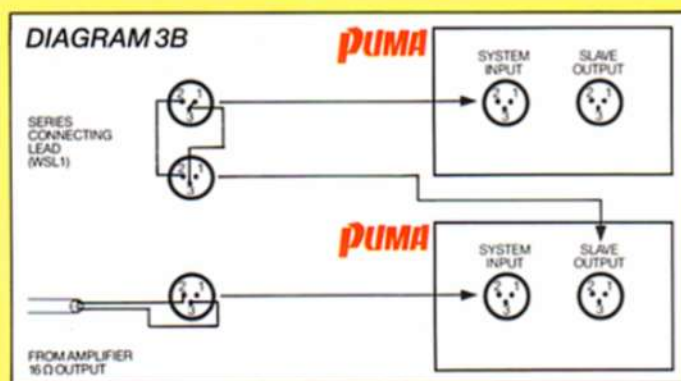
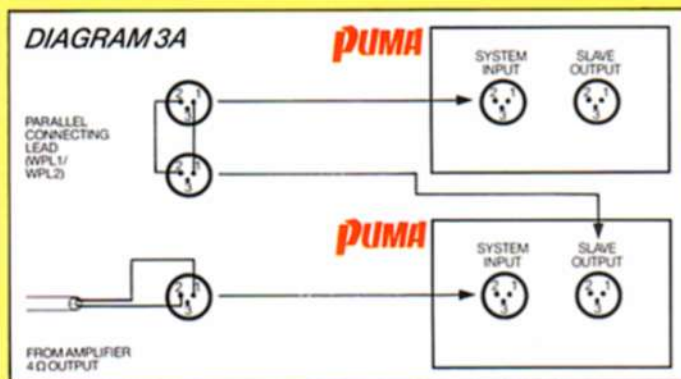
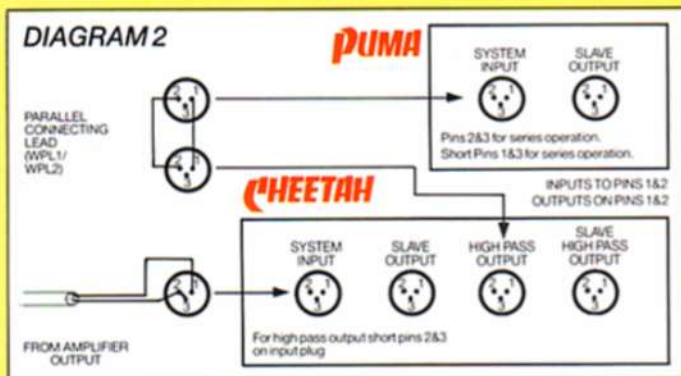

Here are some example combinations of Wildcat loudspeakers that show the flexibility of the system.

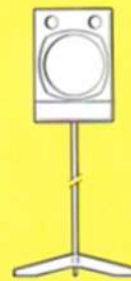

LYNX (AS STEREO SYSTEM)

POWER HANDLING 2 × 200W PROG. (1)
 FREQUENCY RANGE 60Hz – 20kHz
 PEAK SPL 120db
 NOMINAL IMPEDANCE 2 × 8 Ω

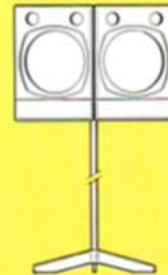

LYNX (LINKED)

POWER HANDLING 400W PROG. (1)
 FREQUENCY RANGE 50Hz – 20kHz
 PEAK SPL 122db
 NOMINAL IMPEDANCE 4 Ω

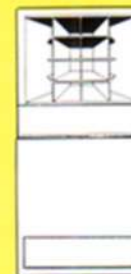

PANTHER + LION

POWER HANDLING (48-90Hz) 300W PROG.
 POWER HANDLING (90Hz-20kHz) 200W PROG. (1)
 FREQUENCY RANGE 48Hz – 20kHz.
 PEAK SPL (48-100Hz) 127db
 PEAK SPL (100Hz-20kHz) 126db
 NOMINAL IMPEDANCE 8 Ω

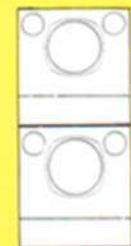

JAGUAR + LEOPARD

POWER HANDLING (35Hz-500Hz) 400W PROG.
 POWER HANDLING (500Hz-20kHz) 300W PROG. (1)
 FREQUENCY RANGE 35Hz – 20kHz.
 PEAK SPL 120db
 NOMINAL IMPEDANCE 8 Ω

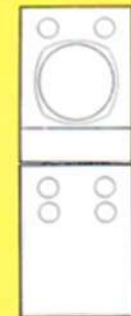

PUMA + CHEETAH

POWER HANDLING (40Hz-100Hz) 400W PROG.
 POWER HANDLING (100Hz-20kHz) 300W PROG. (1)
 FREQUENCY RANGE 40Hz – 20kHz.
 PEAK SPL (40Hz-100Hz) 121db
 PEAK SPL (100Hz-20kHz) 120db
 NOMINAL IMPEDANCE 8 Ω

NOTE (1) Above high pass crossover frequency power is 3db less.



DOCATS'



PUMA

Our little powerhouse, the Puma, packs the punch of the Tannoy 15" dual concentric within a remarkably compact cabinet. A high power system, the Puma is capable of producing the high sound pressure levels required for discotheques, yet with the smoothness and accuracy of sound normally associated with our Studio Monitors. The live performer will also benefit from the outstanding dynamic characteristics. The Puma is a compact and portable system recommended for clubs and cabaret, but with a variety of other applications.

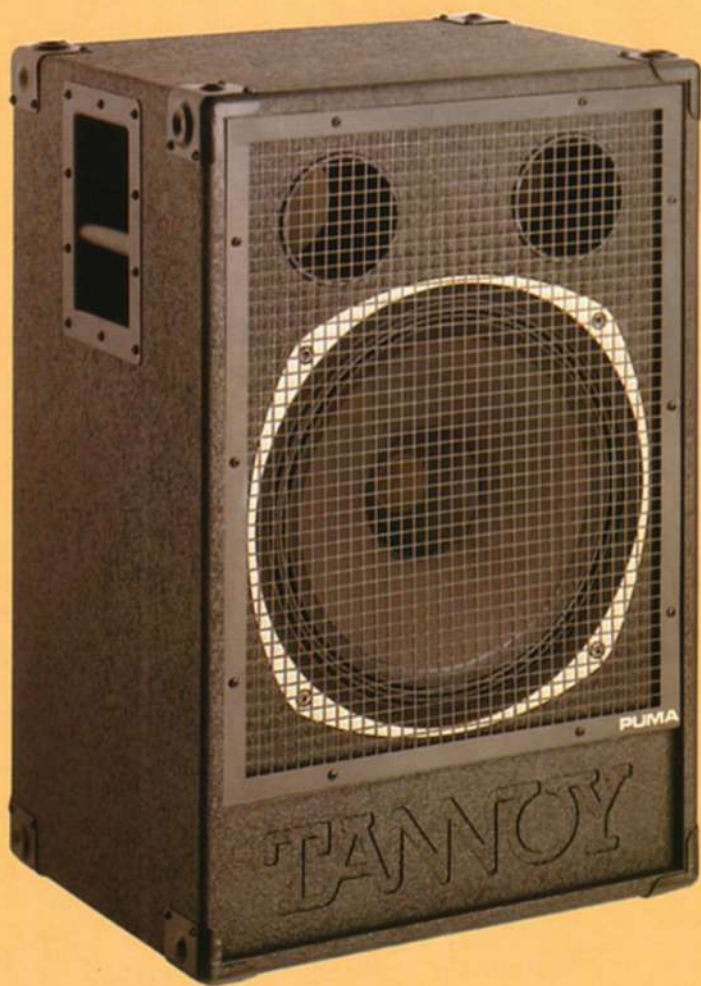

PANTHER

A powerful, yet compact, front loaded horn system that is made possible by the unique Tannoy dual concentric construction. Designed for



with limited space but requiring the bite of extra low frequency.

LEOPARD

A specially designed 15" bass drive unit, using a 3" voice coil, housed within a rigidly constructed cabinet. Unlike many bass bins the Tannoy Leopard has its own internal passive crossover which channels frequencies below 500Hz to its own loudspeaker while frequencies above 500Hz are made available at external sockets to drive other loudspeakers. Tannoy Leopards used in conjunction with other Wildcat Loudspeakers can therefore provide a system with excellent performance without the need for external electronic crossovers, although the connections are sufficiently versatile to allow simple bi-amplification.



LION

A large bass system, similar in concept to the Cheetah. The Lion, however, has a 300 litre enclosure with very high (103db) sensitivity and combines with the Panther to produce a full frequency range system capable of delivering enormous sound pressure levels from a single comparatively modest amplifier.



applications where a long throw is required, the Panther is a highly efficient loudspeaker that will produce astoundingly high sound levels from relatively low power amplifiers.



CHEETAH

An innovative dual cavity bass system designed to provide efficiency over a carefully controlled low frequency band. As with the Leopard, the Cheetah incorporates the uniquely integrated passive crossover network allowing easy connection to other Wildcat systems. Larger systems can, therefore, be built without the need for complicated external electronics or additional numbers of amplifiers. The Cheetah, when added to a Puma or Lynx, provides a compact, wide bandwidth quality P.A. system.



COUGAR

A stage wedge monitor with a controlled response for lack of feedback problems. The unique dual concentric design permits a 15" low frequency driver and a 15" high frequency horn to be integrated within the same chassis. This not only ensures a compact system but also a clean response not found with the majority of stage monitors. Where a performer's priority is quality, the Cougar is the answer.



SPECIFICATIONS

WILDCATS	1/2 LYNX	LYNX	PUMA	JAGUAR	PANTHER	LEOPARD	CHEETAH	LION	COUGAR
Power Handling Programme*	200W	400W	300W	300W	200W	400W	400W	300W	300W
Power Handling RMS (1)	100W	200W	150W	150W	100W	200W	200W	150W	150W
Frequency Range +3dB/-6dB	60Hz-20kHz (2)	50Hz-20kHz (2)	50Hz-20kHz (2)	35Hz-20kHz (2)	80Hz-20kHz (2)	35Hz-500Hz	40Hz-110Hz	48Hz-90Hz	100Hz-20kHz (2)
Sensitivity (3)	94dB	96dB	95dB	94dB	103dB	94dB	95dB	103dB	98dB
Impedance (Nominal)	8 Ω	4 Ω	8 Ω	8 Ω	8 Ω	8 Ω	8 Ω	8 Ω	8 Ω
Impedance (Minimum)	6.5 Ω	3.2 Ω	6.2 Ω	5.8 Ω	5 Ω	6.2 Ω	6.2 Ω	6.2 Ω	5.8 Ω
Dispersion	90° Conical	115° Horizontal 90° Vertical	90° Conical	90° Conical	60° Conical	180° Conical	Omni directional	Omni directional	90° Conical
Crossover Frequency	2.2kHz	2.2kHz	1.8kHz	1.8kHz	1kHz	500Hz	100Hz	100Hz	1.8kHz
Drive Unit	12" dual concentric	2 × 12" dual concentrics	15" dual concentric	15" dual concentric	15" dual concentric	15" Bass	15" Bass	15" Bass	15" dual concentric
Internal Volume	44 litres	2 × 44 litres	104 litres	210 litres	140 litres (4)	210 litres	50L sealed 80L vented	35L sealed 270L vented	46 litres
Finish	Textured Black Paint	Textured Black Paint	Textured Black Paint	Textured Black Paint	Textured Black Paint	Textured Black Paint	Textured Black Paint	Textured Black Paint	Textured Black Paint
Protective Grille	Welded Steel, black finish	Welded Steel, black finish	Welded Steel, black finish	Welded Steel, black finish	Welded Steel, black finish	Welded Steel, black finish	No Grille	Welded Steel, black finish	Welded Steel, black finish
Connections	2 × XLR	4 × XLR	2 × XLR	2 × XLR	2 × XLR	4 × XLR	4 × XLR	4 × XLR	2 × XLR
Dimensions (H × W × D)	486 × 362 × 405/311 mm	486 × 726 × 405/311 mm	726 × 486 × 405 mm	726 × 726 × 511 mm	726 × 726 × 511 mm	726 × 726 × 511 mm	726 × 486 × 581 mm	1068 × 726 × 511 mm	465 × 560 × 432 mm
Weight	19 Kilos	38 Kilos	31 Kilos	44 Kilos	54 Kilos	44 Kilos	34 Kilos	52 Kilos	23 Kilos
Shipping Dimensions (H × W × D)		580 × 790 × 460 mm	790 × 510 × 480 mm	790 × 790 × 590 mm	790 × 790 × 590 mm	790 × 790 × 590 mm	805 × 555 × 580 mm	1145 × 780 × 580 mm	515 × 575 × 495 mm
Shipping Weight		42 Kilos	35 Kilos	50 Kilos	60 Kilos	50 Kilos	39 Kilos	60 Kilos	27 Kilos

NOTES

- (1) Measured with shaped noise signal to EIA RS426. For fundamental frequencies above that of the crossover reduce power by 3db.
- (2) At any power up to RMS rating.
Measured 1 metre on axis in anechoic conditions using swept sine wave.
- (3) Measured in anechoic conditions at 1 metre with 1W input. Some manufacturers measure within half space conditions which can show increased sensitivity at lower frequencies.
- (4) Bass chamber volume.
* Our power handling figures are taken over the entire frequency range of the particular product. Some other manufacturers measure a restricted and often very favourable bandwidth.

Due to our policy of continuous improvement, all specifications are subject to change without notice.

Publication Part No. 6483:0143

ACCESSORIES

- WPL1** 0.5 metre (1.6 feet) parallel interconnecting lead with XLR plugs.
- WPL2** 2.0 metre (6.6 feet) parallel interconnecting lead with XLR plugs.
- WSL1** 2.0 metre (6.6 feet) series interconnecting lead with XLR plugs.
- WA1** Adaptor boss to mount Lynx double cabinet on 1 1/2" tripod stand.
- WA2** Adaptor boss to mount Lynx double cabinet on 1 3/8" tripod stand.
- WTB** Tiebar extender for strapping together two Lynx double cabinets.
- WTS** Adjustable height tripod stand for Lynx and Puma.
- ADP1** Tripod Adaptor for 1 1/4" tripod to 1" fitting.
- ADP2** Tripod Adaptor for 1 3/8" tripod to 1" fitting.

TANNOY

Designed and manufactured in Great Britain by Tannoy Limited, The Bilton Centre, Coronation Road, Cressex Industrial Estate, High Wycombe, Bucks HP12 3SB
Telephone: (0494) 450606
Telex: 83251 TANNOY G
Telefax: (0494) 37431

