

TANNOY®

Definition

DC10A

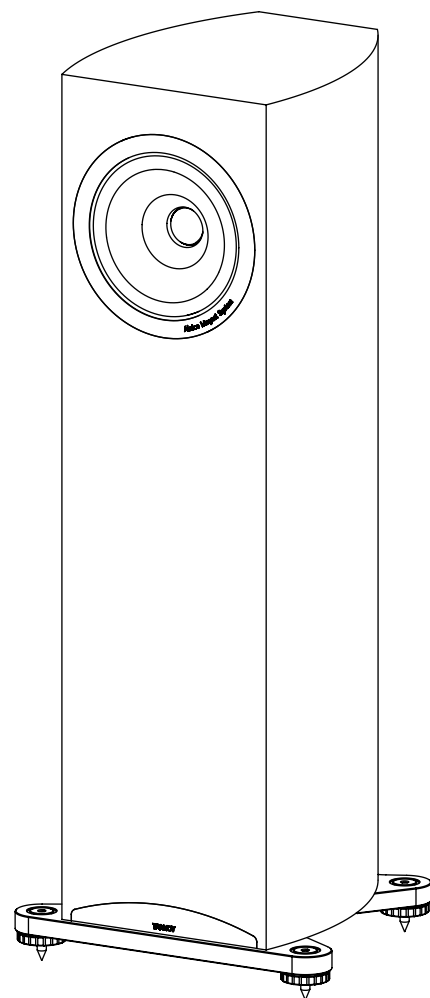

OWNER'S MANUAL

Definition

DC10A

CONTENTS

WARRANTY	02	CONNECTION IN SINGLE WIRE MODE	05
INTRODUCTION	03	CONNECTION IN BI-WIRE MODE	06
WARNING, STRONG MAGNETIC FIELDS	03	BI-AMPING	06
TECHNOLOGY	03	CONNECTION OF EARTH OR 'GROUND' LEAD	06
AMPLIFIER CHOICE	04	POSITIONING AND FINE-TUNING	06
CABLE CHOICE	04	PORT BUNGS	07
UNPACKING	04	GRILLES	07
ACCESSORIES	04	CARE OF CABINET	07
MASS LOADING	05	TECHNICAL SPECIFICATIONS	08
FITTING PLINTHS AND FLOOR SPIKES	05	SETUP DIAGRAMS	09-011
INSTALLATION	05		

WARRANTY

No maintenance of this Tannoy product is necessary.

Please register your Tannoy product online at www.tannoy.com.

All of our products have been produced and tested with care and precision to give first-class service.

All passive components are guaranteed for a period of five years from the date of purchase from an authorised Tannoy dealer subject to the absence or evidence of misuse, overload, or accidental damage.

All active and electronic components are guaranteed for a period of two years from the date of purchase from an authorised Tannoy dealer subject to the absence of, or evidence of, misuse, overload or accidental damage.

If at any time during this warranty period the equipment proves to be defective for any reason other than accident, misuse, neglect, unauthorised modification or fair wear and tear, we will repair any such manufacturing defect or, at our option, replace it without charge for labour, parts or return carriage.

If you suspect a problem with a Tannoy product then, in the first instance, discuss it with your Tannoy dealer. If you require further assistance then we ask that you deal directly with your local Tannoy distributor. If you cannot locate your distributor please contact Tannoy Customer Services, at the address given below.

Customer Services, Tannoy Ltd., Rosehall Industrial Estate, Coatbridge, North Lanarkshire ML5 4TF, Scotland

Telephone: +44 1236 420199

Fax: +44 1236 428230

E-mail: enquiries@tannoy.com

DO NOT SHIP ANY PRODUCT TO TANNOY WITHOUT PREVIOUS AUTHORISATION.

Our policy commits us to incorporating improvements to our products through continuous research and development. Please confirm current specifications for critical applications with your supplier.

INTRODUCTION

Thank you for selecting a Tannoy loudspeaker developed in the UK by our dedicated team of design engineers. They are the choice of discriminating music lovers the world over. Musical excellence is designed into our loudspeakers from the start. Careful selection of the very best components combined with strict quality control procedures in the production process ensures this level of excellence is maintained.

To gain maximum performance from your Definition DC10As, please take time to read this owner's manual in full before installation. Once you have set up your new loudspeakers please complete and return the registration document or register your product online at www.tannoy.com - this does not limit your legal rights.

Loudspeakers are electromechanical devices that 'run-in' through use; performance will therefore improve after an initial period of 24hrs use. Once they have been further run-in over a longer period, there will be clear enhancement of the stereo imaging, mid-band quality and bass performance characteristics.

We are confident that you will continue to enjoy your new Tannoy Definition DC10As for many years to come.

WARNING, STRONG MAGNETIC FIELDS

The powerful magnet system in the Definition DC10A will cause picture distortion with conventional CRT televisions and monitors, and should not be used in the close proximity. There are no issues with plasma, LCD or LED televisions or monitors.

TECHNOLOGY

Alcomax 3 Dual Concentric™

The time coherent, point source and constant directivity nature of the dispersion characteristics inherent in the Dual Concentric drive unit makes it an accepted industry standard in studio monitoring. By exceeding the rigorous demands of the recording and mastering environment Tannoy can ensure that playback performance is strictly controlled to accurately reflect the sound engineer's artistry. In nature all sounds emanate from a single point in space. The high frequency unit of the Dual, centrally mounted in the throat of the main mid/bass driver, is so positioned as to acoustically replicate this single point source; delivering an incredibly natural sound with a very wide imaging 'sweet spot' that creates an expansive soundstage with remarkably focused placement of images.

The DC10A's 10" Dual Concentric driver is derived from the classic Duals found in some of Tannoy's most successful and longest running Prestige series models. Powered by the highest quality Alcomax 3 Alnico motors, this classic driver magnet material has exceptional field strength and is electrically conductive. This minimises non-linear voice coil inductive effects and reduces micro distortions from eddy currents, leading to a sweet, natural and inherently coherent sound.

From instrument amplifiers to guitar pick-ups, Alnico is revered across the music industry for its musicality and dynamics as well as its ability to resolve low level information and texture in the music. Tannoy has long used Alnico drivers in its range topping loudspeakers to best reproduce every note and intonation that the musician intended - a realism rarely achieved by ceramic ferrite motor systems.

The 10" Dual of the DC10A uses the latest iteration of Tannoy's aluminium alloy tweeter with PepperPot WaveGuide™. Mid-and low-frequency reproduction is handled by a multi-fibre cone, allied to the Alcomax 3 magnet assembly engineered to sit on the outside of the voice coils. This configuration delivers the greatest magnetic flux density across the poles, employing to full effect the smoothness and musicality of the Alnico magnet system. Each DC10A driver is hand assembled by Tannoy engineers before being tested and mounted into the cabinet with a unique bracing mechanism.

Audiophile Crossover

High-end components and a 'simple straight' philosophy combine to create a crossover with an ultra-clean signal path. Low loss laminated core inductors ensure optimum LF performance while the HF networks audiophile-grade polypropylene capacitors are acoustically damped using Tannoy's Differential Materials Technology (DMT™) material. Non inductive metal film resistors are used in the high frequency feed. The Definition DC10A crossover sets the benchmark for signal integrity, reproducing music with all the articulation and intelligibility of the original performance.

Deep Cryogenic Treatment

The entire crossover assembly is subject to revolutionary Deep Cryogenic Treatment (DCT), achieving unparalleled gains in resolution and creating a more natural, cohesive sound. Using a proprietary process, the Definition DC10A crossover is super-cooled to minus 190 degrees Celsius and returned to room temperature over a controlled period. This permanently reduces internal stresses in the microstructure of the crossover's component materials, leading to better signal transfer and superior resolution of fine detail. One of the largest benefits is to the solder joints, which are traditionally an area of poor crystalline structure.

AMPLIFIER CHOICE

Consult the product specification as this clearly shows the acceptable power range for amplifier matching to your speakers. The high peak power handling of Tannoy loudspeakers permits responsible use with more powerful amplifiers - please read the Warranty.

As with all loudspeaker systems, the power handling is a function of voice coil thermal capacity. Care should be taken to avoid overdriving any amplifier, as this will cause output overload resulting in 'clipping' or distortion within the output signal. This, if done for any extended period, will cause damage to the speakers.

Generally an amplifier of higher power that is running hard, but free of distortion, will do less damage to the loudspeaker than a lower power amplifier continually clipping. Remember also that a high powered amplifier running at less than 90% of output power generally sounds a great deal better than a lower powered example struggling to achieve 100%. An amplifier with insufficient drive capability will not allow the full performance of the loudspeakers to be realised.

CABLE CHOICE

Always use the best quality of cable available within your budget. High quality audio signals passing from the amplifier to the loudspeaker are unusual in their demands on the cable. Wide dynamic range and frequency bandwidth information has to coexist with the ability to transmit peak currents of at least 10 amps, without incurring any loss or signal impairment. This explains why the sound quality of the information reproduced by the loudspeakers is so dependent on the physical properties of the cables connecting them to the amplifier.

We would recommend that you always keep the cable runs the same length for left and right speakers. Remember, cable construction can affect the sound quality so be prepared to experiment to find a cable that suits your ear and audio system.

UNPACKING

To unpack the loudspeakers from their boxes remove tape from the top then fold the flaps right back before inverting the carton and contents. Lift the carton clear of the contents then remove all inner packaging (See fig.1)

Check carefully for any sign of transit damage. In this unlikely event, notify your shipping company and/or dealer as soon as possible for advice.

It is recommended you store all the packaging to allow protected transport in future.

ACCESSORIES

Check the contents of each accessories box, as follows:

- Plinth section, front x 1
- Plinth section, rear x 1
- Plinth mounting screws x 8
- Floor coupling spikes x 4
- Spike locking wheels x 4
- Spike cups, for floor protection x 4
- Spike adjustment hex tool x 1
- Bi-wiring link cables x 4

Also:

- The front grille is provided in a separate pack within the carton x 1
- Foam port bungs, located in end packaging x 2

MASS LOADING

These loudspeakers are designed to be mass loaded, if wished, to lower the centre of gravity and improve stability, resulting in improved sound quality. To do so, remove the 4 screws securing the access plate to the bottom of the loudspeaker. The loading volume can be filled with sand (which must be dry), or propriety materials available for such purposes from your retailer. Feel free to experiment with the volume of loading material used, to achieve optimum bass performance and stereo imaging. (See fig. 2)

FITTING PLINTHS & FLOOR SPIKES

Attach the two plinth sections using the screws and hex tool provided. These loudspeakers are designed to perform best with the carpet piercing spikes fitted, for optimum stability. These are supplied, along with locking wheels, and should be inserted into the threaded holes in the base of the cabinet. Level the speaker, using the hex tool and then tighten the locking wheels firmly but without using undue force. Spike locating cups are provided in the accessory pack and these may be used to protect sensitive floor surfaces. (Shown also in fig. 2)

Warning:

Ensure that the spikes are levelled and that the lock nuts are tightened firmly. The spikes should be pushed through the carpet to locate into the flooring surface by applying pressure to the top of the cabinet. Failure to do so could render the speaker unsteady and result in damage or injury should it be knocked over.

INSTALLATION

To avoid potential damage to your loudspeaker, ensure that the amplifier is switched OFF prior to connecting or disconnecting any cables. Before switching on double check that all connections are secure and that polarity is correct.

CONNECTION IN SINGLE WIRE MODE

Using the supplied link cables, connect the high frequency (HF) and low frequency (LF) terminals respectively, as shown. These must be removed to Bi-wire the speakers - see section entitled Connection in Bi-wire Mode. For optimum performance in single wire mode, loudspeaker cable connections from the amplifier should be made to the high frequency (HF) terminals of the loudspeaker: (See fig. 3)

- The positive (plus) terminal on the amplifier left channel (marked + or coloured red) must be connected to the positive HF terminal on the left speaker. The left speaker is the one on the left as you look at the stereo pair from your listening position.
- The negative (minus) terminal on the amplifier left channel (marked - or coloured black) must be connected to the negative HF terminal on the left speaker.
- Repeat this connection process for the right speaker. Remember that the positive (+ or red) on the amplifier must be connected to the positive (+ or red) on the speaker and the negative (- or black) to negative.
- Select a signal source, such as a CD player; switch on the amplifier and slowly turn up the volume control to check that both loudspeakers are reproducing bass and treble information.

CONNECTION IN BI-WIRE MODE

Please note in Bi-wire mode that the link cables should not be used. (See fig. 4)

- If not using specially designed bi-wire cable, prepare the two sets of cabling for each 'side' of the system separately. Measure and cut four lengths of cable, two per speaker. Label two of the cable lengths Left LF and Left HF (low frequency and high frequency) then repeat this process for the right pair.
- If your amplifier is not equipped with separate output terminals for bass and treble information then, at the amplifier end of the cables, twist the Left LF+ (positive) and the Left HF+ (positive) together. Connect these to the amplifier Left channel positive terminal marked + (plus) or coloured red.

Twist the Left LF- (negative) and the HF- (negative) cables together and connect them to the amplifier Left channel negative terminal marked - (minus) or coloured black.

At the loudspeaker end connect the cables labelled Left LF+ and Left LF- to the left hand loudspeaker LF terminals, ensuring that you note the polarity markings on the cable sheathing.

Then proceed to connect the Left HF+ and Left HF- to the HF terminals on the same loudspeaker.

- Repeat this process to connect the right hand loudspeaker to the amplifier right channel output, once again ensuring that polarity is correct throughout.
- Switch the amplifier on with the volume control set at its lowest setting. Select a favourite source and slowly turn up the volume to a low level. Check that bass and treble information is being reproduced from both speakers - if not, switch off the amplifier and recheck the connections.

BI-AMPING

Bi-amping extends the principle of Bi-wiring one stage further. In this connection option separate power amplifiers are used for bass and treble signals in each loudspeaker. Four mono (or two stereo) amplifiers of the same type are required for a stereo pair of loudspeakers. Ensure that the cable links between the loudspeaker terminals are removed and that correct polarity is maintained throughout.

If two stereo amplifiers are used, it is recommended that one amplifier supply bass information to left and right loudspeakers and the other treble information. (See fig. 5)

CONNECTION OF EARTH OR 'GROUND' LEAD

Use of a shielded or screened loudspeaker cable will offer further performance advantages when used with the five-way terminal panel. The screening termination should be connected to the earth or ground (white) terminal on the loudspeaker and to the ground or earth connection on the amplifier. Alternatively if you are not using a screened loudspeaker cable but wish to utilise the earthing facility, run a single cable between the earth or 'ground' (white) terminal on the loudspeaker to the earth (ground) connection on the amplifier.

Avoid potential damage to your amplifier - ensure that all connections are secure and the polarity is correct in all wiring. (Method illustrated on all terminal panel sketches)

POSITIONING AND FINE-TUNING

To get best results from your new Tannoy Definition DC10A loudspeakers, it is worthwhile spending a little time finding the optimum set-up configuration.

Begin by angling the speakers towards your chosen listening position, usually this is on the centre line of the room, so that when seated you can just see the inner side panel of each speaker. The front of the loudspeaker should not be obstructed in any way. The loudspeakers should be located between 1.5 to 4.5 metres (5ft to 15ft) apart - with the listening position set slightly further away than the speakers are apart. Avoid positioning the loudspeakers in corners of the room, as this will have a negative effect on performance. Ideally, maintain a distance of at least 0.5 metres (20 inches) from the rear wall, and 1 metre (39 inches) from the side. (See fig. 6).

PORT BUNGS

The Definition DC10A is designed to be operated normally without the foam port bungs in place. However if excessive or poorly controlled bass output results from non-optimal positioning or adverse room acoustics, either one or both bungs may be placed in the rear reflex ports, to damp low frequency output.

GRILLES

The front grille has been designed to provide acoustic transparency. However, for ultimate fidelity the enthusiast will appreciate the slight improvement in clarity and detail that is achieved by removing the grilles during listening. The grilles are held in place by hidden magnets to ensure a neat visual appearance.

CARE OF CABINET

The cabinets should only be cleaned with a dry cloth or with a light application of quality non-silicone furniture polish.

TECHNICAL SPECIFICATIONS

DC10A

PERFORMANCE

Recommended amplifier power (Watts RMS)	30 – 300
Continuous power handling (Watts RMS)	150
Peak power handling (Watts)	600
Sensitivity (2.83 Volts @ 1m)	93 dB
Nominal Impedance (ohms)	8
Frequency response (-6 dB)	28 Hz – 22 kHz
Dispersion (degrees conical)	90

DRIVE UNITS

Dual Concentric™ high frequency	51 mm (2") Aluminium alloy dome, Alnico magnet system with Pepperpot Waveguide™
Dual Concentric™ low frequency	250 mm (10") treated paper pulp cone with twin roll impregnated fabric surround. 52 mm (2") edge wound voice coil, Alnico magnet system

CROSSOVER

Crossover frequency	1.1 kHz
Crossover Type	Bi-wired, hard wired passive low loss 2nd order LF, 2nd order compensated HF, Cryogenically treated

CABINET

Enclosure type	Twin Rear ported
Dimensions H x W x D Inc plinth & grille	1135 x 345 x 438 mm (44.69 x 13.58 x 17.24")
Volume	103 Litres (3.64 cu. ft.)
Weight	42.7 kg (94.1 lbs)

SETUP DIAGRAMS

Fig.1 Unpacking

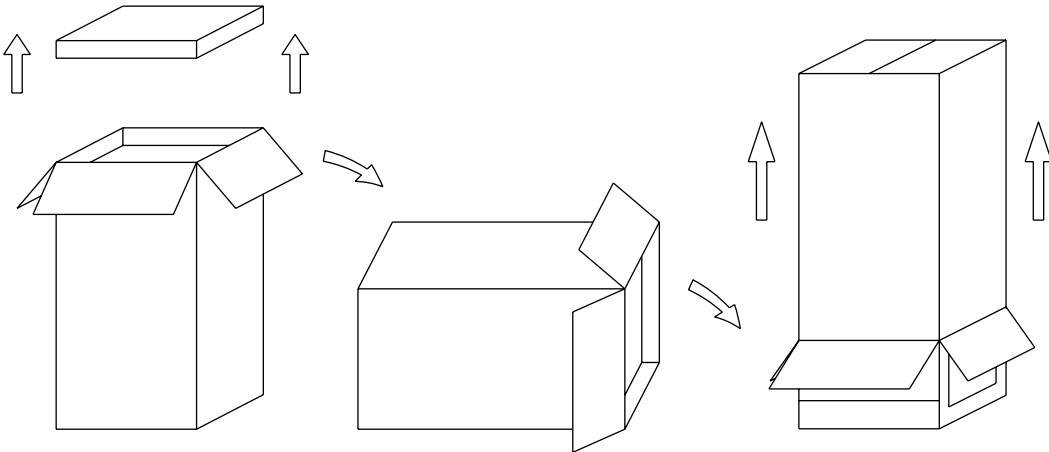

Fig.2 Mass Loading, Fitting of Plinth & Spikes

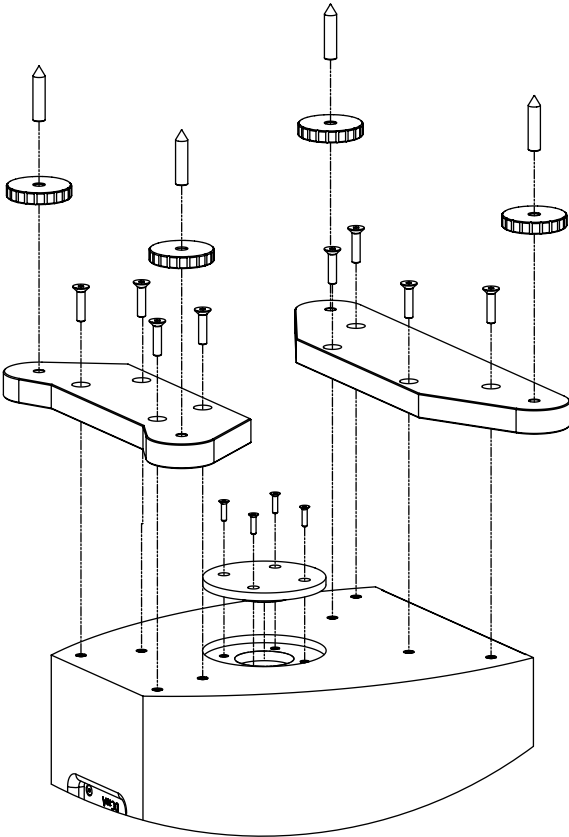
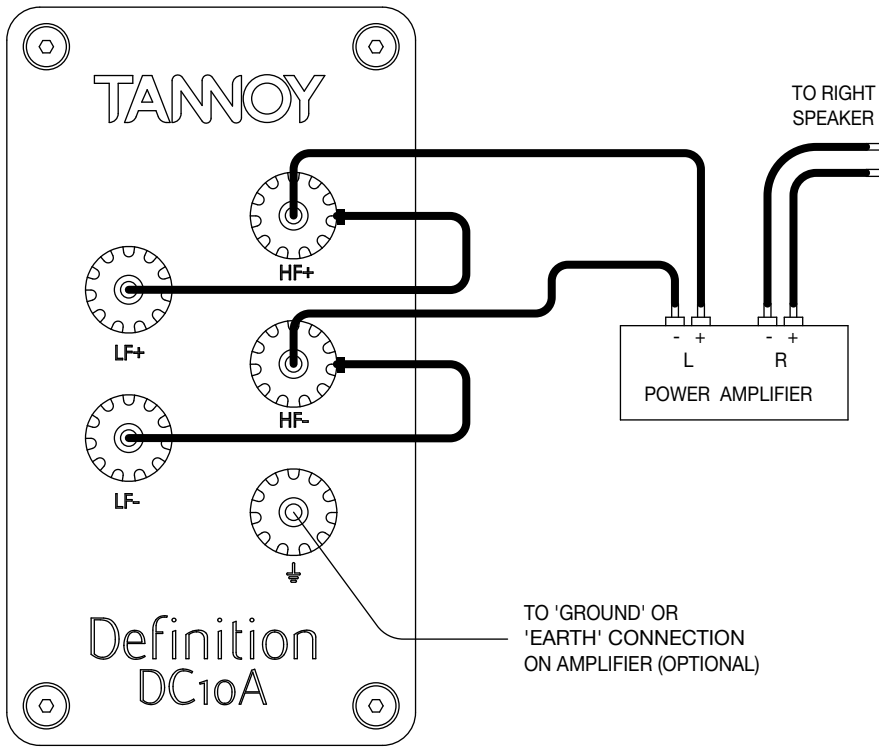
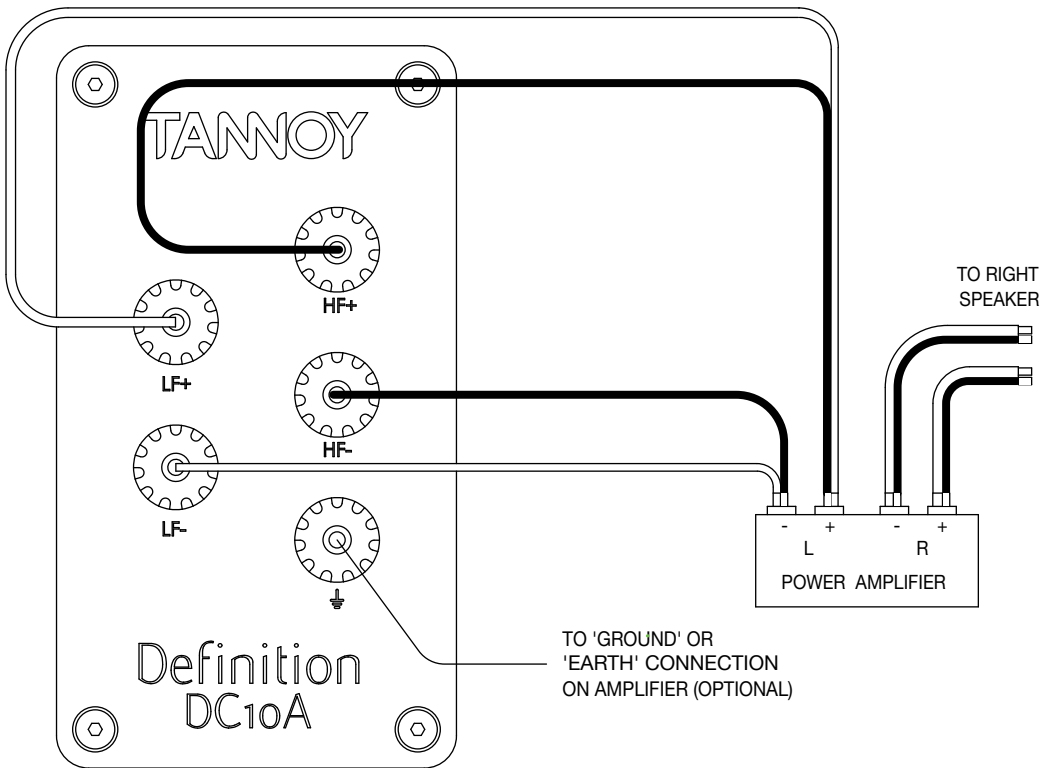

Fig.3 Single Wire Mode



LINKS IN PLACE

Fig.4 Bi-Wire Mode



LINKS REMOVED

Fig.5 Bi-Amp Mode

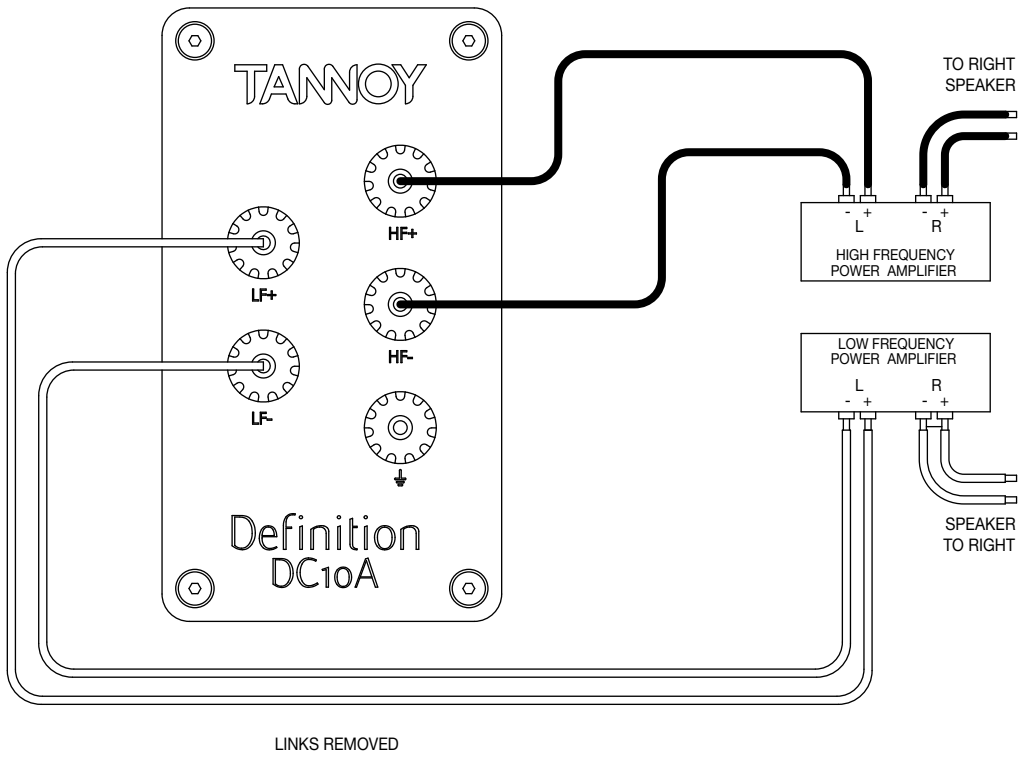
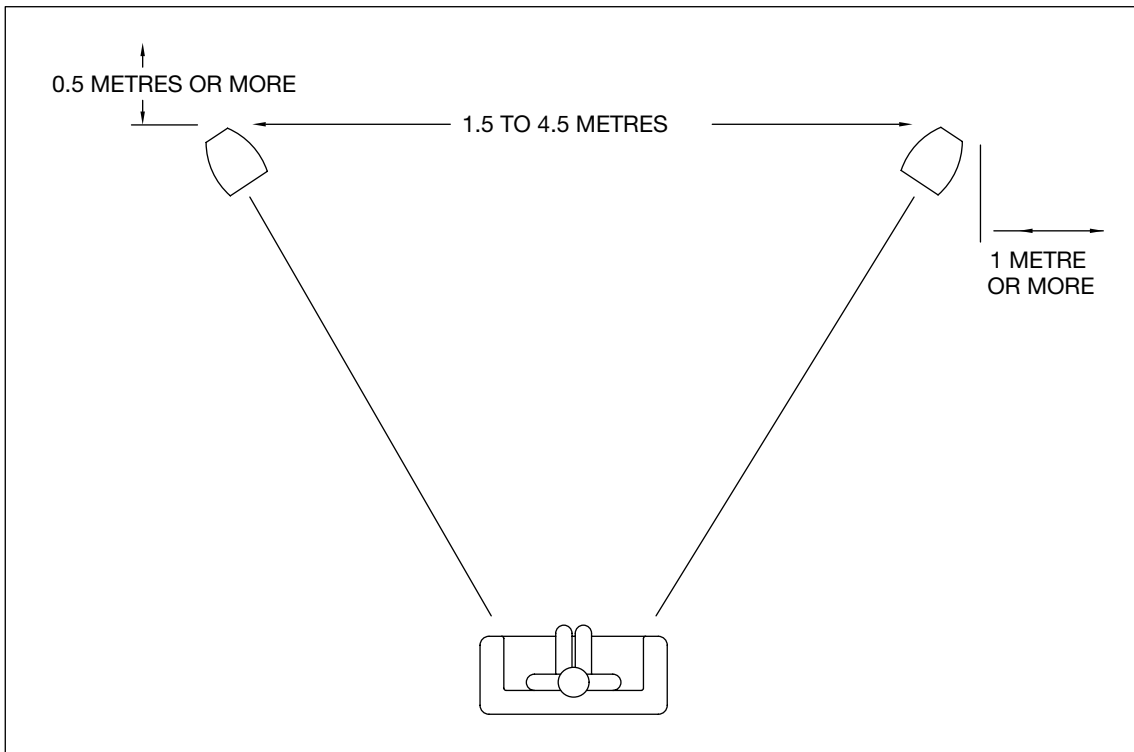

Fig.6 Recommended Positioning



Tannoy Limited - product designed and engineered in the United Kingdom. Tannoy adopts a policy of continuous improvement and product specification is subject to change. Dual Concentric, Differential Materials Technology, WideBand, Tulip WaveGuide, are trademarks of Tannoy Limited. All other trademarks remain the property of their respective owners. Copyright© 2012 Tannoy Limited. All rights reserved.

tannoy.com

