



*Westminster  
Royal <sup>SE</sup>*

*Estd.* **TANNOY** *1926*

# Westminster Royal <sup>SE</sup>

In combining the best of traditional crafts and the latest production and design skills Tannoy presents the Westminster Royal SE loudspeaker. The Westminster Royal SE embodies the Tannoy philosophy. Cabinets in selected hardwoods are hand finished and polished to a standard that is unsurpassed.

The Westminster Royal SE offers a compound horn loaded enclosure driven by classic Dual Concentric™ technology. Based around the Alcomax 3 version of the famous 15 inch Tannoy Dual Concentric™ the Westminster Royal SE now features the benefits of signal handling by gold-plated terminals with bi-wire/normal wiring and a hard wired time compensated crossover network. This Alcomax 3 magnet system endows the Dual Concentric™ with an exceptional transient response and increased sensitivity. The massive cabinet design conceals a complex horn loading system that gives greatly increased efficiency and a wavefront area approaching the wavefront area from real instruments.



The Westminster Royal SE is effortlessly capable of the realistic reproduction of truly low frequencies and the widest dynamic range. Acrolink 99.9999% (6N) high purity copper wiring is used throughout, together with specially selected crossover components, including Hovland capacitors. High frequency energy can be tailored through high current gold-plated switch blocks with controls for both treble energy and roll off.

The specially designed twin-roll impregnated fabric surround used on the drive unit's cone, ensures midrange purity combined with tight, controlled bass.

## *Tannoy - A Short History*

In the early days of broadcasting radio sets needed both low and high voltage DC power that had to be supplied by batteries. The lead acid batteries used in the radio sets of the time needed regular recharging.

In London, in 1926, Guy R. Fountain perfected a new type of electrical rectifier with the aim of designing a charger more suitable for use in the house. His rectifier consisted of two dissimilar metals held in a special electrolyte solution. One metal was Tantalum and the other an alloy of Lead. So successful was this invention that Guy Fountain founded a British Company called Tannoy (a contraction of the words 'Tantalum' and 'Alloy'). Tannoy soon became internationally known and highly regarded in all aspects of sound reproduction.

Moving coil loudspeakers with DC energised magnets began Tannoy's continued success in the field of loudspeaker technology. A discrete two-way loudspeaker system followed in 1933 and shortly after a range of microphones and loudspeakers capable of high power handling.

Tannoy has always been at the front of the communications revolution, developing its own equipment and production technology. The company built a fund of knowledge and experience, that has proved invaluable in the development of loudspeakers for a truly wide range of applications. The now famous Tannoy Dual Concentric™ principle was created and developed under Guy Fountain's direction around 1950. It is highly regarded by music enthusiasts, and recording and broadcast studios because of its unique properties in faithfully reproducing sound to an unusually high quality standard.

Guy Fountain retired from the company in 1974 but the Tannoy company continues his philosophy dedicated to the accurate and realistic reproduction of music for both enthusiasts and professionals around the world.

The Tannoy Research and Development unit has further refined the innovative Dual Concentric™ principle. Using the latest design and material technologies, with sophisticated circuit techniques in crossover design, Tannoy has produced a loudspeaker system with superb reproductive capabilities and exceptionally wide dynamic range.

Tannoy is now part of the TG Group, whose goal is to design, produce and distribute the best engineered, most recognised and respected brands of high performance audio products in the world.

## *Unpacking Instructions*

**CAUTION:** This loudspeaker weighs 138 kg (304 lbs). Do not attempt to unpack single handed. Never allow the weight of the loudspeaker to be taken at any stage by the solid walnut mouldings at the top of the cabinet. Do not lift the cabinet by using the top solid walnut mouldings.

Although the solid walnut mouldings are securely tongued and grooved into the cabinet carcass, they do not have sufficient strength to withstand the full weight of the cabinet.

Two methods are recommended for unpacking. The choice depends on particular local circumstances.

### **METHOD 1 (5 PERSONS)**

Remove the cardboard packing to reveal the loudspeaker standing on the transit pallet. Locate and remove from the carton the accessories pack. Lift the loudspeaker vertically up off the pallet by 100 mm (4") to clear the interlocking pallet. Remove the pallet and lower the loudspeaker to the ground. The loudspeaker may then be wheeled conveniently into position.

### **METHOD 2 (3 PERSONS)**

Remove all packing beneath the top cap to reveal the top of the loudspeaker and mark the face of the carton immediately behind the back panel of the loudspeaker. Locate and remove from the carton the accessories pack.

Replace the top packing and top cap; tape the top packing in place to prevent movement. Invert the loudspeaker by rolling over onto the back panel and rolling over again onto the top cap. Do not roll over onto the front or side panels. Remove the wooden pallet and roll the loudspeaker back again using the marked face of the carton only. Remove the outer cardboard carton and end cap to reveal the loudspeaker. The loudspeaker may then be wheeled conveniently into position.

**IMPORTANT:** It is essential that only the rear top edge of the cabinet is used as the hinge point in rolling the cabinet over. If any stress is placed on the front or side top edges they may be damaged.

Examine all pieces of packing material and inspect the carton for signs of external damage. If there is evidence of excessive damage to the packaging and resulting damage to the loudspeaker inform the carrier and supplier immediately. Always keep the packing in such circumstances for subsequent examination. Tannoy strongly suggests that you store the complete packaging set for possible future use.

## *Initial Positioning*

Place the loudspeakers with their back panels close against a wall for best results. A starting point of 400 mm (15<sup>3</sup>/<sub>4</sub>" ) from the back wall is recommended. Remember that the proximity of the loudspeakers to walls and corners will affect the sound. Some experimentation will probably be needed to fine tune the stereo image depth and low frequency sound quality. Stereo image separation and depth will be improved by toeing-in the cabinets towards the listening position. The axes of the cabinets can even intersect at a point slightly in front of the listening position. Close-to-wall positions and room corners more so, have the effect of increasing very low frequency sound energy. Reflective adjacent walls may upset the stereo image by causing unwanted reflections.

When the optimum position for the loudspeakers has been determined, position the three metal cups provided in the accessories pack, so that they sit under the three support cones, on the underside of the loudspeaker. These are positioned one at the front and two at the rear. This will give maximum stability, and enable your loudspeakers to provide their full dynamics and resolution of detail.

**WARNING:** This operation should be carried out by two people, to avoid the risk of personal injury, should the speaker slip or fall.

## *Amplifier Connections*

Connect the loudspeakers to the amplifier using a high quality cable. Your dealer will be able to make recommendations. The terminals will accept either spade or banana plugs. If not bi-wiring fit the link wires from the accessories pack, as shown in figure 2.

Arrange the connections so that the right hand amplifier channel terminals are connected to the right hand loudspeaker as viewed from the listening position.

Correct polarity of the connections between the amplifier and speakers is essential. The positive terminal on the amplifier left channel, marked +(plus) or coloured red, must be connected to the positive terminal on the left loudspeaker. The negative terminal on the amplifier left channel, marked -(minus) or coloured black, must be connected to the negative terminal on the left loudspeaker.

Repeat this connection for the right speaker.

Good quality cables and tight, well-made connections are necessary to eliminate resistive losses and maintain the correct damping of the loudspeaker by the amplifier.

## *Amplifier Connections Cont.*

If the cables and connections have been made correctly as described above the loudspeakers will be automatically in phase with each other. However if phasing is felt to be incorrect (for example, diffuse stereo image, lack of bass) then apply the following test:

Place the loudspeakers side by side and play a monophonic signal from the amplifier, choosing the programme material with a strong bass content. If phasing is correct bass will be full and rich. If incorrect there will be very little bass due to cancellation effects. Incorrect phasing can be remedied by reversing the connecting leads to one loudspeaker (at either the amplifier or the loudspeaker terminals but not both).

**Note:** Be certain to ensure that the amplifier is switched off when connecting or disconnecting loudspeaker leads. Amplifiers fitted with output capacitors can damage the loudspeaker under these circumstances. Also accidentally shorting the loudspeaker leads together can damage some amplifiers. Such damage is outside warranty provisions.

## *Bi-Wiring Theory*

Loudspeakers need power signals to produce acoustic energy when reproducing music. The range of electrical currents passing down the cable from the amplifier to the loudspeaker is very wide. In decibel terms this is called the dynamic range. Modern loudspeakers are capable of resolving a dynamic range of at least 80 dB with a suitable power amplifier.

An 80dB dynamic range corresponds to voltages of between 50 Volt and 0.005 Volt at the loudspeaker terminals or equivalent currents of between 0.0006 and 6 Amp. This is a truly wide range of electrical signals to pass down one cable without some interactions causing a loss of resolution in the very small signals.

When electricity passes down a wire or cable, what does in at one end is unfortunately different from what comes out at the other. The degree of loss or modification of a signal depends on the physical characteristics of the cable and the nature of the signal. Heavy electrical currents flowing down thin conductors cause heating effects. Very high frequency signals passing along conductors or cables of certain lengths cause electromagnetic radiation effects (aerials). Electrical cables are selected for minimum loss and maximum information resolution considering the type of electrical signals they are designed to carry.

A good solution to the problem is to 'bi-wire' the loudspeakers to the amplifier. This means providing two separate sets of cables from the power amplifier to each loudspeaker and dividing the electrical signals into high current, 'slow' signals and light current, 'fast' signals. Of course, the loudspeaker must be fitted with two pairs of terminals to take the two sets of cables; your Tannoy loudspeakers are of course equipped for just this type of connection.

## *Bi-Wiring*

Bi-wiring releases the full potential of the Tannoy Prestige loudspeakers. Two complete sets of cable are required.

Switch the amplifier off. Deal with each 'side' of the system separately. Label two of the cables Left LF and Left HF (low frequency and high frequency).

Label two of the cables Left LF and Left HF (low frequency and high frequency). Do the same for the right pair. Undo the loudspeaker terminals, remove and retain the Bi-wiring links so that the same polarity terminals are no longer joined.

It is essential to get the polarity correct. If your amplifier does not have separate output terminals for bass and treble then, at the amplifier end of the cable, connect the Left LF+ and HF+ cables together. Then wire to the amplifier Left channel positive terminal marked + (plus) or coloured red.

Connect the Left LF- and HF- cables together to the amplifier negative terminal marked - (minus) or black.

Note the polarity marking on the cable. At the loudspeaker end connect the cables marked Left LF+ and LF- to the appropriate left speaker LF terminals. Connect the Left HF+ and HF- to the appropriate + and - left speaker HF terminals.

Make the same connections with the Right LF and HF cables. Note the polarity of the cable and be sure to connect + to + and - to -; the LF cables to LF terminals and HF to HF.

For optimum performance, the earth connection on the terminal panel should be connected to the amplifier chassis earth or other ground point. This screening effect can give an improvement in detail clarity, depending on the amplifier used. Optimum results are achieved using a screened loudspeaker cable designed for such a system, such as the Tannoy TLC.

Switch on the amplifier with the volume turned down. Select a favourite source and carefully turn up the volume. Check that bass and treble sounds come from both speakers. If not, switch off and remake the connections.

**FIG. 1** TERMINAL PANEL CONNECTIONS

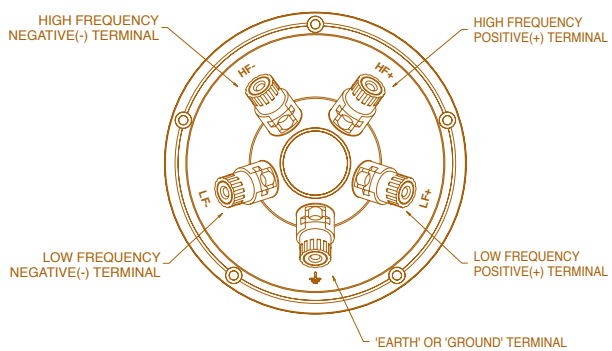

**FIG. 2** SINGLE WIRE MODE AND EARTH (GROUND) LEAD CONNECTION

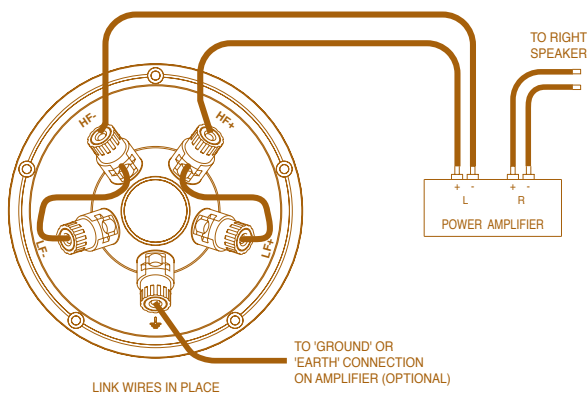

**FIG. 3** BI-WIRE MODE AND EARTH (GROUND) LEAD CONNECTION

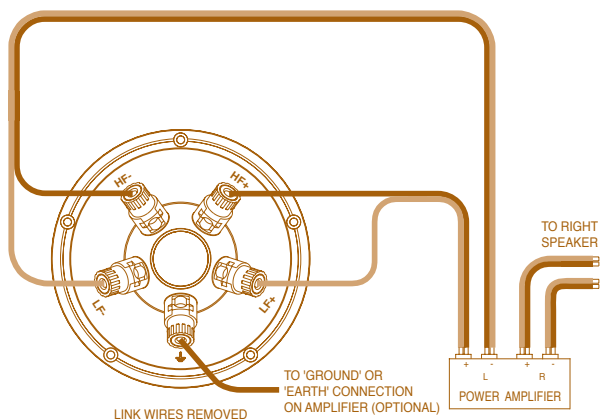

**FIG. 4** BI-AMPING MODE AND EARTH (GROUND) LEAD CONNECTION

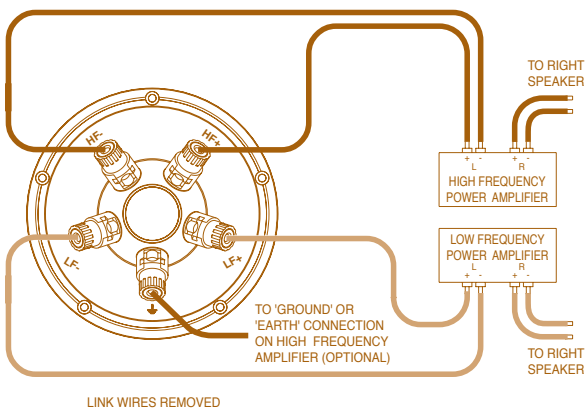

## *Cables*

High quality audio signals passing from power amplifier to loudspeaker are unusual in their demands on cable. Frequencies from 20Hz to 20kHz (10 octaves or a ratio of 10,000:1) and currents of 80dB dynamic range (again a ratio of 10,000:1) have to coexist. The cable also has to be capable of transmitting peak currents of at least 10 Amp without causing losses greater than 0.001 Amp (10 Amp divided by the ratio 10,000). These strict requirements on loudspeaker cables help explain why the sound quality from loudspeakers is so dependant on the physical properties of the cables connecting them to the power amplifier.

## *Grille Removal*

Special acoustically transparent cloth is used in the grilles. However, for ultimate fidelity the enthusiast will find it is best to use these loudspeakers with their grilles removed during listening.

The large front grille is removable for access to the front panel controls. Insert the key provided into the lock at the bottom of the main grille assembly and turn anti-clockwise to release. Pull the bottom of the grille away from the cabinet; the grille will drop down from its upper location. Take care not to damage the solid walnut lower part of the cabinet. To replace the grille engage the top of the grille into the slot in the cabinet and push the grill into the recess. Apply slight pressure to the bottom whilst turning the key clockwise to engage the lock.

The side grilles are service removable only, by pulling them away from locating dowels mounted on the cabinet. Do not use excessive force and take care not to damage the solid walnut mouldings.

## *Loudspeaker System Adjustment*

Each loudspeaker is fitted with two controls located on the front baffle beneath the detachable grille. These high current switch blocks are labelled ROLL OFF and ENERGY. They can be used to compensate for the varied acoustic characteristics of listening rooms. The controls should be adjusted with the amplifier tone controls in the 'flat' or uncompensated position. Each loudspeaker should be adjusted individually. This is most easily done by rotating the amplifier balance control to select first one loudspeaker and then the other.

The ENERGY control has five positions. It allows the output of the high frequency compression drive unit to be increased or decreased from the linear or 'flat' position over a frequency band from approximately 1kHz to 20kHz.

The ROLL OFF control has five positions (+2, level, -2, -4 and -6dB per octave) and provides adjustment at extreme high frequencies from 5kHz to 20kHz.

The ENERGY control has a shelving effect over the 1kHz to 20kHz frequency band whereas the ROLL OFF control increases or decreases the slope of the extreme high frequency response hinging about 5kHz.

The flattest, most linear response from the loudspeaker will be obtained with both controls set at the LEVEL position, and this position should be used for initial listening tests. If the overall high frequency sound quality seems too prominent the -1.5 or -3 positions for the ENERGY control should be tried. If the sound appears subdued in the treble region +1.5 or +3 settings may be preferred. Once the ENERGY control setting has been established the ROLL OFF control can be adjusted to reduce or slightly increase the extreme high frequency content if necessary.

Remember the changes that can be made by moving either control from one position to another are subtle. They may not easily be heard if the programme material has very little content in the frequency band under consideration. Choose a well balanced piece of music with a full spectrum of sound. The correct setting will be found when the loudspeakers are no longer evident and only the musical performance is heard.

## *Running in*

Like all loudspeakers, the drive unit in your Westminster Royal SE requires a while to reach optimum performance, as the stresses in the materials relax - especially in the suspension system. For this reason, it is beneficial to run the system at fairly high levels at normal room temperature, for approximately 20 hours to achieve best results.



## *Tannoy Dual Concentric™ Drive Unit*

One of the unique advantages of the Tannoy Dual Concentric™ principle is that the low and high frequency sound radiation is generated on the same axis. The high frequency unit is mounted behind, and concentrically with, the low frequency unit. High frequency sound radiates from the centre of the low frequency unit through a carefully designed high frequency exponential horn. Low and high frequencies are therefore fully integrated at source. It is this feature that gives the Dual Concentric™ driver such unique sound reproduction qualities.

There are other significant benefits. The high frequency unit does not obstruct the low frequency unit in any way (a unique feature when compared with other so called coaxial systems). Polar dispersion of sound is symmetrical in both horizontal and vertical planes. By careful crossover network design the virtual acoustic sources of the high and low frequency units can be made to occupy the same point on the axis. Therefore the total sound appears to emanate from a single point source located slightly behind the drive unit. This means that a full and accurate stereo image can be recreated by the loudspeakers when fed from a high quality stereo source.

### *The Low Frequency Section*

The low frequency section of the Dual Concentric™ driver is a high compliance unit of exceptional power handling and dynamic range. The low frequency cone piston is produced from selected paper pulp. This is specially treated to absorb internal resonance modes. The completed cone is fitted with unique rigid reinforcing members to attain a very high stiffness to mass ratio thereby preserving piston action over the operating frequency range.

The twin roll fabric surround is also damped and shaped correctly to terminate the moving cone and provide optimum compliance and linearity at large excursions. The cone piston is driven by a high power motor system consisting of a four-layer coil suspended in a precision magnetic air gap. The coil is wound with a special high temperature adhesive system and individually cured to ensure reliable operation at high peak power inputs. The shape of the low frequency cone is arranged to provide optimum dispersion of audio frequencies at both the high and low ends of the spectrum. The cone flare continues the high frequency horn profile to ensure a smooth transition at the crossover point.

### *The High Frequency Section*

The high frequency driver consists of a wide dynamic range compression unit giving superb transient performance with a smooth uncoloured response. The compression unit feeds acoustic power through a multiple phase compensating device to the throat of a solid steel acoustic horn. This horn provides an acoustic impedance transformation to match the compression unit radiation into the listening environment.

A magnesium alloy diaphragm formed by a specially developed five-stage process produces a piston with a very high stiffness to mass ratio. Optimum molecular grain structure gives long term durability. A very low mass precision aluminium coil provides the driving force for the diaphragm, with fine multistranded copper lead out wires to ensure reliability. A rear damped acoustic cavity controls the compression driver response and ensures further correct acoustic impedance matching to the horn throat.

The response of the compression horn driver extends a full two octaves below the crossover frequency to eliminate colourations that can arise through operation over the fundamental resonance region.

### *The Magnetic Circuit*

An Alcomax 3 high energy magnet provides flux generation for both high frequency and low frequency driving motors. Precision air gaps contain the magnetic flux surrounding each coil. The high frequency air gap has a unique shunt member to apportion the total magnetic flux in the correct ratio between low and high frequency units. This gives an optimum acoustic balance. Precision machined, low carbon steel pole pieces ensure unsaturated operation, linear flux fields and a high heat sinking capability. High power inputs can therefore be handled with minimum change of impedance due to temperature effects. A very robust, high quality, precision pressure die-cast chassis locates the whole magnet assembly and positions the moving parts with high accuracy. This provides long term reliability and yet does not interfere with the acoustic radiation from the individual sections.

### *Alcomax Magnet*

Alcomax 3 is an unusually high energy permanent magnet. The unusual iron / nickel alloy is doped with cobalt, aluminium and other rare metals to produce a magnetic material with very special properties. Alcomax 3 has a high remanent magnetism and energy product. In other words, it magnetises to a high level and retains that unusual degree of magnetisation. Alcomax 3 is also an electrical conduction. These properties give the Dual Concentric™ drive unit using an Alcomax 3 magnet an exceptionally clean transient response and increased sensitivity.

## *The Crossover Network*

During the design of the crossover network the acoustic, mechanical and electrical interactions of the high and low frequency sections have been fully analysed. The crossover is therefore an integral part of the design of the system. The crossover network provides complex equalisation in both amplitude and phase for each section and fully integrates the response at the crossover point. All components are high precision, low-loss and thermally stable. A unique shunt element technique controls the motional impedance of the drive units.

All components in the crossover network are hard wired to eliminate unwanted metal-to-metal contact and ensure freedom from vibration. The components are laid out to minimise inter component coupling and are placed well away from the driver magnetic field. Specially selected components of the highest quality are used, such as Hovland polypropylene capacitors, non inductive thick film resistors with extensive heat sinking, and very low loss laminated iron core inductors. Wiring is by Acrolink (99.9999% purity) copper, having a large crystal structure and stable atomic arrangement.

High current switch blocks with gold-plated screw terminals permit user adjustment of high frequency sound radiation to suit differing listening environments.

The complementary design of crossover and drive units means that the loudspeaker system as a whole behaves as a minimum phase system over the audio band and therefore the acoustic sources of the high and low frequency sections are aligned in time and space to ensure accurate reproduction of stereo images.

## *A Note on Auditory Perception*

Our hearing mechanism locates natural sound sources with great accuracy by using the naturally occurring phase differences (or arrival times) at middle frequencies, and intensity differences at higher frequencies, between each of our ears. Naturally occurring sounds pass through the air to the ears at constant speed (345 metres/second or 1132 feet/second). All frequencies travel at the same speed and therefore a frequency independent time delay is associated with the distances involved. (The familiar time delay between a flash of lightning and the associated clap of thunder is an example).

Human hearing relies on the constant nature of the time delay with the intensity to locate natural sounds accurately. A pair of Tannoy Prestige loudspeakers can uniquely reconstruct stereo images and provide excellent localisation of recorded sounds. The Tannoy Dual Concentric™ principle ensures that the source of sound at high frequencies is on the same axis as the source of sound at low frequencies.

The careful design of crossover network complements the drive unit to provide a coincident sound source at frequencies where the human ear derives phase information for localisation. The loudspeaker system exhibits a time delay response that is in essence independent of reproduced frequencies. In addition, the amplitude (or intensity) response is linear, smooth and consistent. This provides the correct intensity information to recreate the original sound stage.

## *The Westminster Royal SE Compound Horn Loudspeaker - Technical description*

A horn loudspeaker consists of an electrically driven diaphragm coupled to a horn shaped device. The horn increases the coupling between the oscillating diaphragm and the listening environment by increasing the air loading presented to the diaphragm. Ordinary direct radiating loudspeakers are relatively inefficient because the energy present in the moving diaphragm is not transmitted to the air particles in the listening environment particularly efficiently.

The presence of a horn, loading the diaphragm, greatly increases the resistive portion of the air load and more energy can be transferred to the environment for a given diaphragm energy.

Conversely, for a given level of sound generated by a horn loaded diaphragm, the amplitude of movement of the diaphragm will be lower than for the equivalent sound level generated by a direct radiating loudspeaker. Therefore the distortions present in the diaphragm at larger amplitudes will be reduced further, because the diaphragm has a larger air load that has a higher resistive value and also because the damping on the diaphragm will be greater. This results in a better transient performance.

The compound horn loudspeaker consists of a diaphragm with one side of the diaphragm coupled to a straight axis horn and the other side coupled to a long folded horn.

The Westminster Royal SE cabinet generates both horns using a rigid network of 30 individual panels. The internal construction is not easy to visualise. **Figure 5** shows a perspective view of the internal construction of the rear folded horn with the front straight axis horn removed for clarity.



Figure 6 shows a developed section through the horn with the rear folded horn straightened out for clarity. This gives an acoustic engineering model that can be used to describe how the compound horn operates.

Figure 7 shows the electrical analogue of the acoustic system shown in developed cross section.

$M_{MS}$  and  $C_{MS}$  represent the moving mass and suspension compliance of the drive unit respectively.  $Z_f$  represents the acoustic load impedance presented to the driver by the front horn and  $Z_r$  the impedance presented by the rear horn. The volume of the air between the driver and the throat of the rear horn behaves as an acoustical compliance (capacitance) shown in the network as  $R_{MS}$  in parallel with  $Z_r$ .

**FIG. 5**

Perspective view of Westminster Royal SE cabinet with front horn section removed to show the internal construction of the horn development comprising the rear folded horn. The arrows show the direction of radiation from the drive unit to the listening environment.

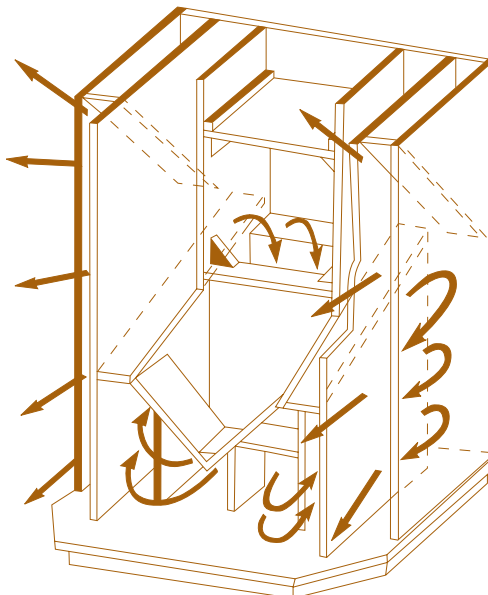

**FIG. 6**

Acoustic engineering model of compound horn system

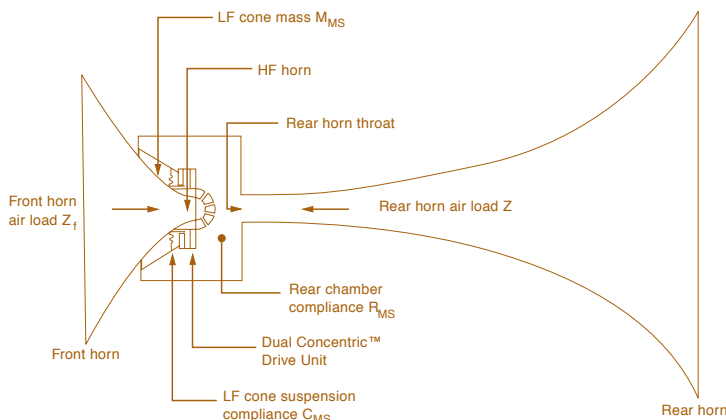

**FIG. 7**

Electrical analogue of acoustic system

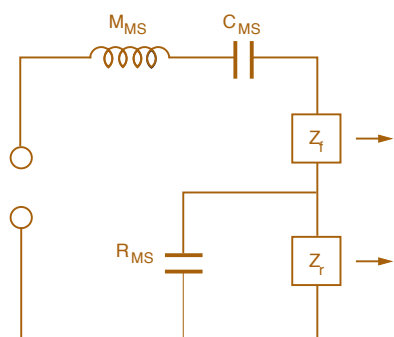

At 300 Hz both horns radiating -6 dB

**FIG. 8**

Electrical analogue - behaviour at low frequencies

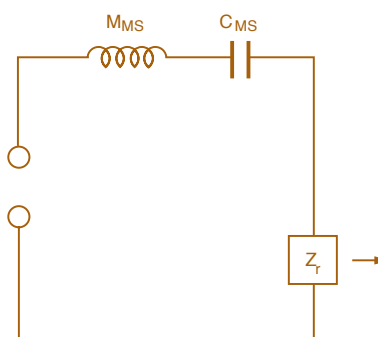

Below 300 Hz rear horn radiates ( $Z_r$  low resistance,  $R_{MS}$  high reactance) (power dissipates in  $Z_r$ )

Figure 8 shows that although the drive unit is a two way system (low frequency cone, and high frequency compression unit) the total system behaves as a three way loudspeaker with the lower crossover point, at 300 Hz, performed by the acoustical mechanism of the cabinet.

## *Care of the Cabinet*

The cabinet is constructed from carefully selected solid walnut and walnut veneers that have been hand waxed before dispatch from our finishing workshop.

To maintain the natural wood appearance it is important that only a wax of similar formulation is used.

A jar of specially formulated wax is included with each loudspeaker. This wax should be applied very sparingly with a soft lint-free cloth (muslin for example) taking great care to avoid putting wax on the grille material. If necessary mask off the side grilles carefully with clean paper, tucking it in and around the sides of the grilles. Work the wax into the wood covering a small area at a time.

In common with all solid wood furniture, exposure to extremes of heat, cold and varying humidity will cause the wood to ease slightly. Therefore it is recommended that the loudspeaker is protected from environmental extremes to guard against any such occurrence.

## *Faultfinding*

Tannoy loudspeakers are designed and manufactured to be reliable. When a fault occurs in a hi-fi system the effect is always heard through the loudspeakers although they may not be the source of the fault. It is important to trace the cause of the problem as accurately as possible.

A fault heard on one source (only CD or tape for instance) is most unlikely to be a loudspeaker problem. Loudspeakers do not generate hum, hiss or rumble although high-quality, wide-bandwidth loudspeakers may emphasise such problems.

## *Tannoy Quality*

An important part of Tannoy's design philosophy is to produce loudspeakers with a level of performance beyond the most exacting specifications of contemporary source equipment.

Loudspeaker design is no longer a 'black art'. It is now possible to use computers to model designs and predict results. Comprehensive test equipment is used to pin-point problems with cabinets or drive units; anechoic chambers help in producing accurate measurements. Computer aided design (CAD) and sophisticated test equipment are used extensively at Tannoy but we always remember that listening tests must be the final judge.

Tannoy follows a policy of stringent quality control procedures using sophisticated measurement facilities. Strict quality control is more easily achieved because all the loudspeakers are built in-house at the Tannoy factory in Scotland. All drive units are designed and manufactured by Tannoy. All incoming parts are thoroughly tested to ensure that they are as specified. Not only is all data computerised but CAD ensures every loudspeaker meets or exceeds our exacting standards.

## *Warranty and Service*

Tannoy Prestige loudspeakers will operate for many years without trouble provided they are cared for as instructed.

Tannoy Prestige loudspeakers are warranted against manufacturing defects in material or craftsmanship over a period of 5 years from the date of purchase. This warranty is in addition to your statutory rights as a customer. Tannoy cannot however be held responsible for failures caused by abuse, unauthorised modifications, improper operations or damage caused by faults elsewhere in your system.

The determination of the cause of failure will be made by Tannoy Ltd or its authorised Distributor or Service Agent based on physical inspection of the failed parts.

If you suspect a problem with your loudspeakers then in the first instance discuss it with your Tannoy Dealer. The Dealer has the expertise and experience to help you troubleshoot the system and assess the situation.

If you continue to have problems contact your Tannoy Distributor or Tannoy Customer Services at our Coatbridge address.

Due to our policy of continuous improvement, all specifications are subject to change without notice.

## *Caution*

The high peak power handling of Tannoy loudspeakers will allow responsible use with larger amplifiers on wide dynamic range material.

Take care with any amplifier, irrespective of power output, to avoid abnormal conditions such as switch-on surges or output overload (clipping) that may result in peaks of power greatly over the rated output.

## Technical Specifications

### PERFORMANCE

---

<b>RECOMMENDED AMPLIFIER POWER</b>	50 - 225 Watts per channel
<b>POWER RATING</b>	135 Watts RMS 550 Watts peak
<b>MAXIMUM SPL</b>	120.5dB (135 Watts RMS / 1m) 126.5dB (550 Watts peak / 1m)
<b>SENSITIVITY</b>	99dB (2.83 Volts @ 1m)
<b>NOMINAL IMPEDANCE</b>	8 Ohm
<b>FREQUENCY RESPONSE</b>	18Hz - 22kHz
<b>DISPERSION</b>	90 degree conical
<b>TOTAL HARMONIC DISTORTION</b>	Less than 1% at 135 Watts RMS (50Hz - 20kHz)

### DRIVE UNIT

---

<b>DRIVER TYPE</b>	380mm (15") Dual Concentric™ utilising paper pulp cone with twin roll impregnated fabric surround
<b>LOW FREQUENCY</b>	52mm (2") round wire voice coil
<b>HIGH FREQUENCY</b>	51mm (2") round wire voice coil

### CROSSOVER

---

<b>CROSSOVER TYPE</b>	Bi-wired, hard-wired passive, low loss, 2nd order LF, 2nd order compensated HF
<b>CROSSOVER FREQUENCY ADJUSTMENTS</b>	200Hz Acoustical, 1.0kHz electrical +/-3dB over 1.0kHz to 22kHz shelving +3dB to -6dB per octave over 5.0kHz to 22kHz slope

### CABINET

---

<b>ENCLOSURE TYPE</b>	Compound horn
<b>VOLUME</b>	530 litres (18.7 cu.ft.)
<b>DIMENSIONS</b>	1395mm (54 <sup>5</sup> / <sub>16</sub> ") x 980mm (38 <sup>9</sup> / <sub>16</sub> ") x 560mm (22 <sup>1</sup> / <sub>16</sub> ") (H x W x D)
<b>WEIGHT</b>	138 kilograms (304 lbs)
<b>CONSTRUCTION</b>	Solid walnut with birch ply Internally crossbraced and heavily damped

### PACKAGE DETAIL

---

<b>DIMENSIONS</b>	1590mm (62 <sup>5</sup> / <sub>8</sub> ") x 1080mm(42 <sup>1</sup> / <sub>2</sub> ") x 660mm (26") (H xW x D)
<b>WEIGHT</b>	154 kilograms (339.5 lbs)

# TANNOY®

Tannoy United Kingdom	T: 00 44 (0) 1236 420199	E: <a href="mailto:enquiries@tannoy.com">enquiries@tannoy.com</a>
Tannoy North America	T: 00 1 (519) 745 1158	E: <a href="mailto:inquiries@tannoyna.com">inquiries@tannoyna.com</a>
Tannoy Deutschland	T: 00 49 (0180) 1111 881	E: <a href="mailto:info@tannoy.com">info@tannoy.com</a>
Tannoy France	T: 00 33 (0)1 7036 7473	E: <a href="mailto:ventes@tannoy.com">ventes@tannoy.com</a>

[tannoy.com](http://tannoy.com)